

Camici e Cotte



Glesant



Glesant

ALB

CAM11S-A / B

Camice celebrante collo rivoltato con piegoni e cerniera sulla spalla

PL 65% CO 35%

Colori: A avorio - B bianco

Colors: A Ivory - B White



CAM13-A / B

Camice celebrante collo rivoltato senza piegoni manica raglan

PL 65% CO 35%

Colori: A avorio - B bianco

Colors: A Ivory - B White



CAM11-A / B - Camice con cerniera sul davanti

CAM11C-B - Camice 100% cotone bianco

CAM69-A / B - Camice in misto lana

CAM13C-B - Camice 100% cotone bianco

CAM13L-B - Camice 100% lino bianco



CAM12-A / B

Camice con piegoni e finto cappuccio



Glesant

ALB

CAM14-A / B

Camice celebrante collo finto cappuccio senza
piegoni manica raglan
PL 65% CO 35%
Colori: A avorio - B bianco
Colors: A Ivory - B White



CAM15- A / B

Camice celebrante collo romano
PL 65% CO 35%
Colori: A avorio - B bianco
Colors: A Ivory - B White



CAM72- A / B - Camice in misto lana
coat in wool blend



Glesant

ALB

CAM60-A / B

Camice celebrante con piegone e tramezzo cm 12 JHS
PL 65% CO 35%
alb with fold



CAM64-A / B

Camice benedettino
PL 100%
benedictine alb



CAM76-A / B - Camice collo quadro con tramezzo
cm 12 JHS
PL 55% WO 45%

COT60-A / B - Cotta con tramezzo cm 12 JHS
PL 65% CO 35%

CAM70-A / B - Camice benedettino in misto lana
CAM98-A / B - Camice benedettino misto cotone
CAM98C-B - Camice benedettino 100% cotone

Colori: A avorio - B bianco
Colors: A Ivory - B White



Glesant

ALB

CAM40S-A

Camice collo rivoltato tramezzo macrame' croce greca
PL 65% CO 35%

Color: Ivory

AVORIO





Glesant

ALB

CAM40S-AO

Camice collo rivoltato tramezzo macramè croce greca

PL 65% CO 35%

Color: Ivory/gold

AVORIO/ORO





Glesant

ALB

CAM92-B

Camice con macramè cm 60
PL 55% WO 45%

CAM97-A / B

Camice con marquesette cm 70
PL 55% WO 45%



COT90-B - Cotta con macramè cm 60 bianca

CAM97-A / B - Camice collo quadro con marquesette cm 70

COT83-A / B - Cotta con marquesette cm 70 in misto cotone

COT91-A / B - Cotta con marquesette cm 70 in misto lana

Colori: A avorio - B bianco

Colors: A Ivory - B White

Camici e Cotte



Glesant

ALB

CAM50-B

Camice con tulle ricamato cm 70 su fondo rosso

PL 65% CO 35%

Color: White

BIANCO





Glesant

ALB

CAM36S-A

Camice collo rivoltato c/spalla con bordo catena

PL 65% CO 35%

Color: Ivory

AVORIO



Camici e Cotte



Glesant

ALB

CAM47S-A

AVORIO

Camice collo rivoltato c/spalla Finto Gigliuccio 5 giri

PL 65% CO 35%

Color: Ivory



Camici e Cotte



Glesant

ALB

CAM48S-A

Camice collo rivoltato c/spalla Finto Gigliuccio 5 giri
PL 65% CO 35%

Color: Ivory

AVORIO



Camici e Cotte



Glesant

SURPLICE ROMAN COLLAR

COT90-B

Cotta con macramè cm 60
PL 55% WO 45%

Color: White

BIANCO

COT82-A

Cotta con macramè cm 60 punto Filet
PL 65% CO 35%

Color: Ivory

AVORIO





Glesant

SURPLICE ROMAN COLLAR

COT76-A / B

Cotta con ricamo gigliuccio 5 giri tipo papale avorio
PL 55% WO 45%



COT50-B

BIANCO
Cotta con ricamo macramè su tulle cm 70 bianco
PL 65% CO 35%
Color: White



COT73-A - Cotta con ricamo gigliuccio 1 giro

COT74-A - Cotta con ricamo gigliuccio 2 giri

COT74-A - Cotta con ricamo gigliuccio 3 giri

CAM77-A - Camice con ricamo gigliuccio 1 giro

CAM78-A - Camice con ricamo gigliuccio 2 giri

CAM79-A - Camice con ricamo gigliuccio 3 giri

CAM80-A - Camice con ricamo gigliuccio 5 giri



Glesant

SURPLICE ROMAN COLLAR

COT38L-B

Cotta con macramè h 60 calice
CO 75% LI 25%

Color: White

BIANCO

COT37-B

Cotta con macramè h 60 croce cuore
PL 65% CO 35%

Color: White

BIANCO



SURPLICE ROMAN COLLAR



Glesant

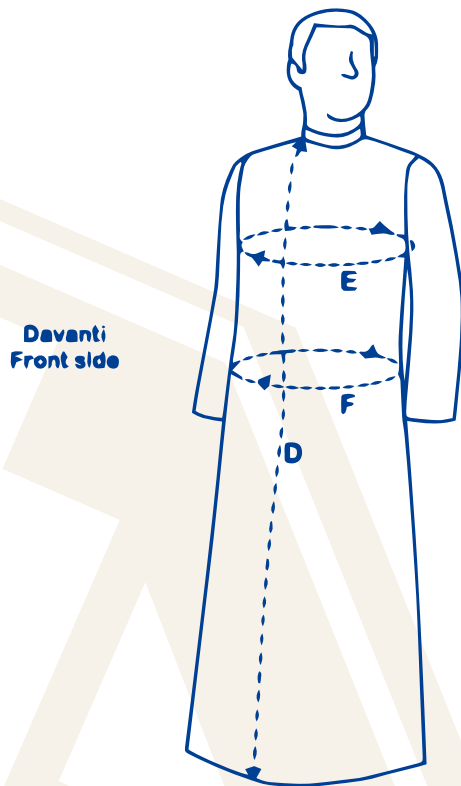

Davanti
Front side

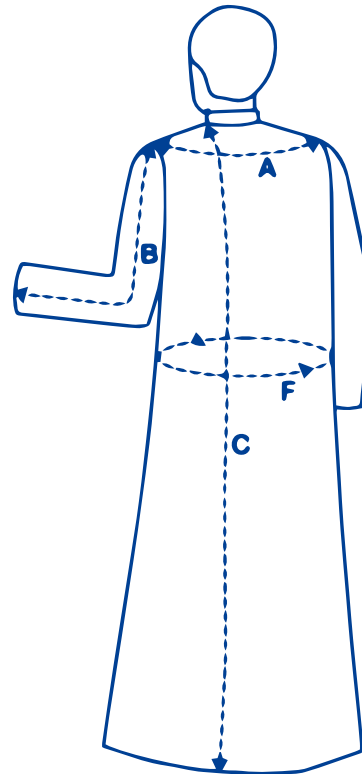

Dietro
Back side

A = Larghezza Spalla da attacco braccia.

B = Lunghezza braccio da attacco spalla.

C = Lunghezza totale dietro da attaccatura collo/spalla.

D = Lunghezza totale davanti da attaccatura collo/spalla.

E = Circonferenza torace da sotto le braccia.

F = Circonferenza vita.

Cm. _____

Cm. _____

Cm. _____

Cm. _____

Cm. _____

Cm. _____

COLLO CAMICI Alb collar



1



2

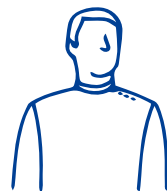

3

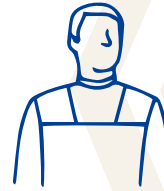

4



5

1 = Collo rivoltato tipo coreana.

2 = Collo rivoltato sul davanti e finto cappuccio sul dietro.

3 = Collo rivoltato tipo coreana con cerniera sulla spalla.

4 = Collo quadro alla romana.

5 = Collo ad anello tipo benedettino.

La GLESANT Srl si riserva per esigenze di modellistica, eventuali piccole variazioni delle misure senza l'obbligo di comunicazione.